

KOMATSU®

D51EXi-24

D51PXi-24

Tier 4 Final Engine

CRAWLER DOZER

D51i



Photos may include optional equipment.

NET HORSEPOWER

131 HP @ 2200 rpm
98 kW @ 2200 rpm

OPERATING WEIGHT

D51EXi-24: 30,380 lb 13780 kg
D51PXi-24: 31,438 lb 14260 kg

BLADE CAPACITY

Power Angle Tilt (PAT) Dozer:
D51EXi-24: 3.5 yd³ 2.7 m³
D51PXi-24: 4.4 yd³ 3.4 m³

WALK-AROUND

Next-generation intelligence

Improved machine efficiency for work ranging from heavy dozing to finish grading with intelligent Machine Control technologies.

Lift layer control

Realizes consistent lift layers with automatic control.

Quick surface creation

Makes design data by easy operation.

Proactive dozing control

Cut and carry work smooth as if performed by experienced operator.

Tilt steering control

Relieves operator of correction operation toward target point.

Adopts two antennas supporting multiple global navigation satellite system (GNSS)

Improved reliability in work accuracy due to stable receiving of satellite signals.

Information and communication technology (ICT) system installed as standard before shipment

Improved reliability and durability.



Photo may include optional equipment.

NET HORSEPOWER

131 HP @ 2200 rpm
98 kW @ 2200 rpm

OPERATING WEIGHT

D51EXi-24: 30,380 lb 13780 kg
D51PXi-24: 31,438 lb 14260 kg

BLADE CAPACITY

Power Angle Tilt (PAT) Dozer:
D51EXi-24: 3.5 yd³ 2.7 m³
D51PXi-24: 4.4 yd³ 3.4 m³

D51EXi/PXi-24



INNOVATIVE. INTEGRATED. INTELLIGENT.

Standard intelligent Machine Control 2.0
Standard factory-installed integrated 3D
GNSS intelligent machine control system.

Improved Machine Control
Up to 8% more efficient dozer operation
than comparable aftermarket machine
control systems in start to finish
grading tests.

Factory Installed Machine Control Components

Machine control components are factory installed and designed as an integral part of the base machine for improved durability.

Komatsu Quality

Machine control components and system validated to Komatsu's rigorous quality & durability standards.

Industry Standard Compatibility

Machine control system makes use of common industry design data file norms and supports typical base station communication.

Simple Operator Interface

Simple touchscreen control box with multi-color customizable display.

3D GNSS Machine Control (Standard)

All on-machine components are standard, including control box, GNSS receiver/radio, GNSS antenna, and enhanced inertial measuring unit sensor.

Finish Grade Performance

Enhanced sensor package and intelligent logic provides for finish grade accuracy in an integrated system without traditional blade-mounted sensors.

Enhanced Inertial Measuring Unit (IMU+)

Chassis-mounted enhanced inertial measuring unit (IMU+) and intelligent logic provides for finish grade accuracy without blade-mounted sensors.

Dual Cab Top GNSS Antennas

Load control intelligence controls blade elevation to improve productivity and minimize track slip by adjusting blade load. 1.0' from grade or 0.1' from grade – you can run in auto mode.

Intelligent Dozing Mode Settings

Operators are able to select between 4 distinct machine control operating modes to optimize performance to the application whether cutting, spreading, or other.

Operator Selectable Load Settings

Machine control load settings can be adjusted between presets to tailor response to material conditions.

New Operator Identification System (standard) provides KOMTRAX data for machine operation and applications for up to 100 individual ID codes.

SAA4D107E-7 water cooled variable geometry turbocharged and aftercooled 4.5 liter diesel engine provides excellent fuel economy. This engine is EPA Tier 4 Final emissions certified.

Komatsu Diesel Oxidation Catalyst (KDOC) and Selective Catalytic Reduction (SCR) systems reduce particulate matter and NOx using passive regeneration 100% of the time. No active or manual regeneration is required.



Photos may include optional equipment.

Efficient Cooling System:

- Electronically controlled, hydraulically-driven fan can be easily reversed through the monitor
- Rear hinged radiator guard with gas assisted lift cylinders opens easily for cleaning
- Side-by-side single plane coolers help reduce chances of plugging and simplify maintenance

Integrated ROPS cab features:

- Large, quiet, pressurized cab
- Exceptional visibility with super slant nose design and integrated ROPS structure
- Heated air-ride seat with high capacity suspension (standard)
- Standard aux jack and (2) 12V power converters

Improved durability:

- Heavy-plate steel used for the nose and the hydraulic and fuel tanks
- Dozer frame with full steel castings
- Komatsu-designed and manufactured components

Standard Parallel Link Undercarriage System (PLUS) provides up to double the wear life and lowers repair and maintenance costs compared to a standard undercarriage design.

New Triple Labyrinth Final Drive Shield design provides additional protection for the final drive floating seals.

Power Angle Tilt (PAT) dozer with manually adjustable blade pitch increases productivity in a variety of applications.

INTELLIGENT MACHINE CONTROL

D51EXi/PXi-24



Photo may include optional equipment.

intelligent Machine Control (iMC) 2.0

D51EXi/PXi-24 utilizes intelligent Machine Control 2.0 a GNSS* system that automatically controls the blade to 3-dimensional design data. Machine Control 2.0 utilizes the industry's first Proactive Dozing Control logic, lift layer control, quick surface creation, and tilt steering control. A two-antenna system supporting multiple GNSS, which provides less downtime and more work time. These added features make for improved production and efficiency.

*GNSS (Global Navigation Satellite System): General term for satellite positioning systems such as GPS, GLONASS, etc.

Quick surface creation

Operators can create a temporary design surface with the press of a button. Designed to simplify in-field surface creation within the control box, it allows for more utilization of iMC 2.0.



Tilt steering control

The blade automatically tilts under a heavy load to maintain a straight line of travel, optimizing productivity throughout each pass and reducing operator fatigue.



Auto/manual switch

A conveniently located on/off switch giving the operator control of when iMC 2.0 is active.



Function switches

Cut/fill offset switch

The target surface height can be quickly adjusted by pressing the offset switch (button).

Back grade mode switch

Allows for automatic control during back grading.



Cut/fill offset switch

Back grade mode switch

Lift layer control

Optimize earthwork productivity and maintain compaction quality by automatically controlling lifts to the desired heights with respect to the mapped terrain. Excess fill is eliminated as automatic blade control will follow finish surface once lifts have reached finish grade.

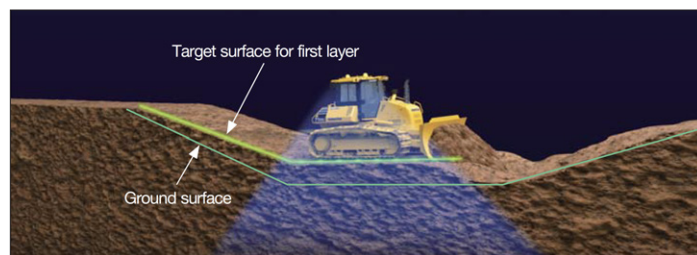

Proactive dozing control

Operators can utilize automatic blade control from rough grading to finish grading work. Proactive dozing control understands the terrain in the path of each cut, maximizes the blade load throughout the pass, regardless of the terrain ahead, and achieves productivity similar to that of an experienced operator.

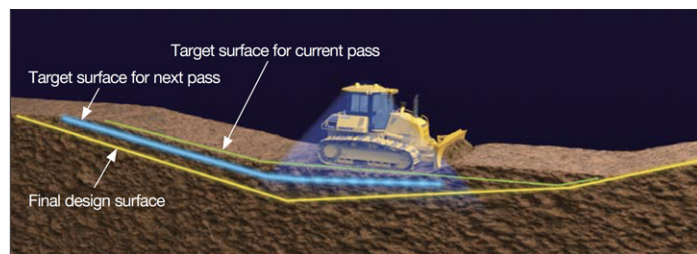

Two antennas supporting multiple GNSS

Work accuracy is improved by two antennas supporting the multiple GNSS.

Improvement of blade accuracy on slope

Blade accuracy is maintained during slope work.

Reliability of blade accuracy

Galileo, QZSS, and BeiDou can be used in addition to GPS and GLONASS. Since the satellite capture rate is improved, the machine can be used in any time zone.



Control box

- 1 L.H. LED indicator 2 Upper LED indicator
- 3 R.H. LED indicator
- 4 Power ON/OFF and menu switch (Press: Display the main menu / Hold down: Turn ON/OFF the power supply)
- 5 Zoom in switch 6 Zoom out switch
- 7 Toggle main view switch (Press: Switch the display of main window / Hold down: Adjust the brightness and sound volume)
- 1 Left window 2 Main window 3 Lower window
- 4 Right window 5 Speed control ON/OFF
- 6 Take a topo shot 7 Simple grading ON/OFF
- 8 Cut depth selection 9 Smooth start ON/OFF
- 10 Tilt steering ON/OFF 11 Toggle As-built mode change view to [none], [cut fill], [pass counts]
- 12 Quick surface creation (Create slope plane surface)
- 13 Lift layer control (Create As-built design surface)
- 1 Elevation control key 2 Slope control key
- 3 GNSS status 4 Radio status 5 Cut/Fill offset
- 6 Cut/Fill reading 7 Tilt of blade
- 8 Design cross-slope 9 Type of control
- 10 AUTO indicator 11 Back Grade mode indicator
- 12 Lift indicator

*This is a typical main screen of control box.



PERFORMANCE FEATURES

KOMATSU NEW ENGINE TECHNOLOGIES

Komatsu's New Emission Regulations-compliant Engine

New regulations effective in 2014 require the reduction of NOx emissions. In addition to refining the U.S. EPA Tier 4 Interim technologies, Komatsu developed a new Selective Catalytic Reduction (SCR) device in-house.

- ① Komatsu Diesel Oxidation Catalyst (KDOC)
- ② Water-cooled variable geometry turbocharger
- ③ Komatsu Closed Crankcase Ventilation (KCCV)
- ④ SCR

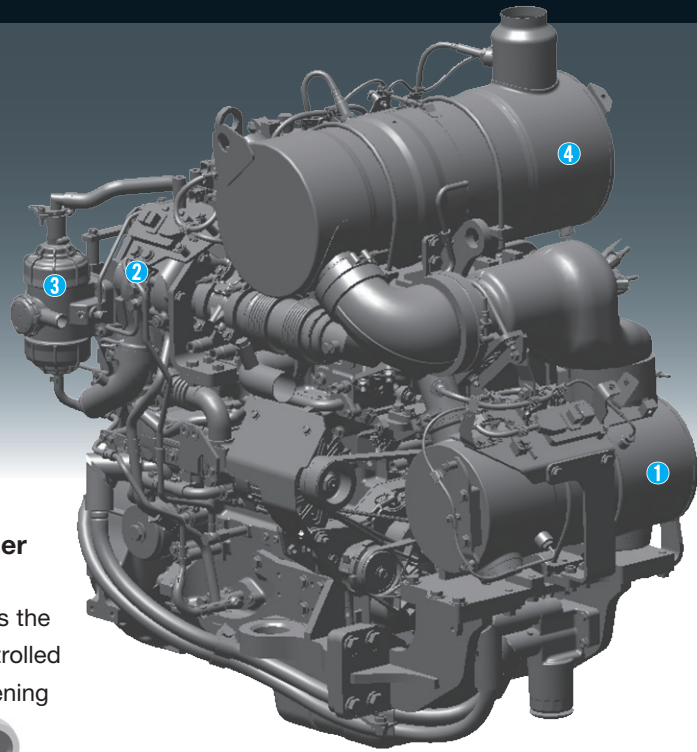

Technologies Applied to New Engine

Water cooled variable geometry turbocharger

A newly designed variable geometry turbocharger features simple and reliable technology that controls the intake air-flow. Exhaust turbine wheel speed is controlled by the nozzle ring which varies the exhaust gas opening to provide the optimal volume of air to the engine combustion chamber under all speed and load conditions. The result is cleaner exhaust gas while maintaining power and performance.

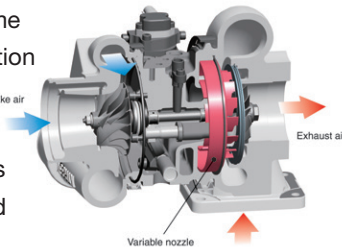

Cooled Exhaust Gas Recirculation (EGR)

Cooled EGR, a technology well-proven in existing Komatsu engines, reduces NOx emissions. These components ensure reliable performance during the demanding work conditions of construction equipment.

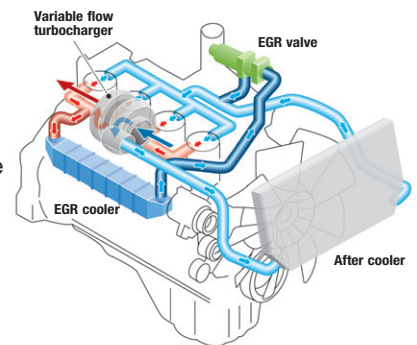

Heavy-duty aftertreatment system

This new system consists of a KDOC and a SCR. The SCR NOx reduction system injects the correct amount of Diesel Exhaust Fluid (DEF) at the proper rate, thereby decomposing NOx into non-toxic water (H₂O) and nitrogen gas (N₂).

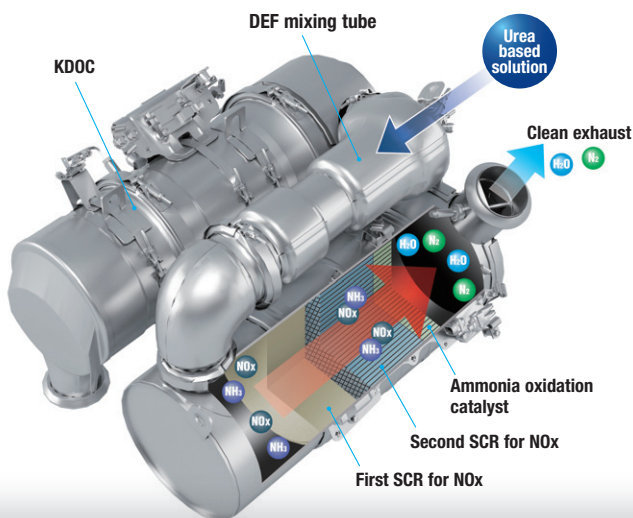

Komatsu Closed Crankcase Ventilation (KCCV)

Crankcase emissions (Blowby gas) are passed through a KCCV filter. The KCCV filter traps oil mist which is returned back to the crankcase while the gas, which is almost oil mist free, is fed back to the air intake.



D51EXH/PXH-24

Heavy-duty High Pressure Common Rail (HPCR) fuel injection system

The system is designed to achieve an optimal injection of high-pressure fuel by means of computerized control, thereby bringing close to complete combustion to reduce Particulate Matter (PM) emissions. While this technology is already used in current engines, the new system uses higher-pressure fuel injection, thereby reducing both PM emissions and fuel consumption over the entire engine power range.

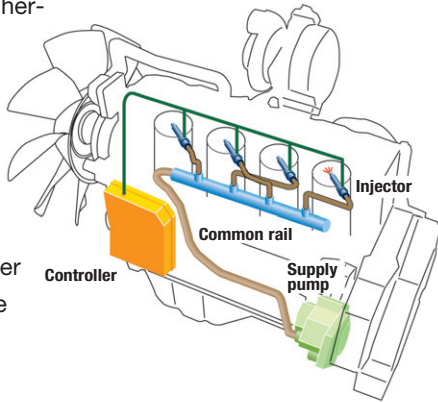

Advanced electronic control system

The electronic control system performs high-speed processing of all signals from sensors installed in the vehicle and engine. This ensures total control of the equipment under all conditions. Engine condition information is displayed via an on-board network on the monitor inside the cab. Furthermore, KOMTRAX helps customers use this information to keep up with maintenance needs.

Redesigned combustion chamber at top of piston

The combustion chamber at the top of the piston has a new shape designed to improve combustion and further reduce NOx, PM, fuel consumption and noise.

Auto Idle Shutdown Function

Komatsu auto idle shutdown automatically shuts the engine down after idling for a set period of time to reduce unnecessary fuel consumption and exhaust emissions. The amount of time before the engine is shutdown can be easily programmed from 5 to 60 minutes.

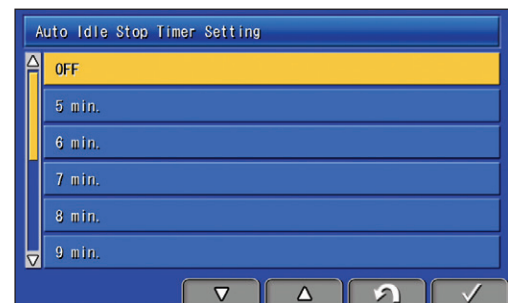

PRODUCTIVITY & FUEL ECONOMY FEATURES

HYDROSTATIC TRANSMISSION (HST) CONTROL SYSTEM

HST Control System

The HST controller monitors engine output and work load. It controls HST pump and motor displacement to provide the optimum speed and drawbar pull. Full power to both tracks during turns or counter-rotation makes the D51EXi/PXi-24 extremely maneuverable.



Fuel Efficiency

The efficient electronically controlled HST system can reduce fuel consumption.

Fuel consumption reduced by up to 13%

Compared with D51EXi/PXi-22 in P mode
Based on typical work pattern collected via KOMTRAX

Hydraulically Driven Cooling Fan

The engine cooling fan's speed is electronically controlled. Fan speed depends on engine coolant and oil temperatures. The fan will only rotate as fast as is necessary to adequately cool the machine's fluid. This system increases fuel efficiency, reduces operating noise levels and requires less horsepower than a belt-driven fan.

Long Track-On-Ground and Oscillating Track Frame

Long machine track-on-ground and oscillating track frames improve stability and grading/dozing performance.

Selectable Working Mode

P mode is the mode designed for powerful operation and maximum production. E mode is designed for general dozing applications, providing adequate speed and power, while saving energy. For fuel reduction and energy savings, the monitor panel allows the operator to easily switch between working modes, depending on working conditions.

P mode (Power mode)

With P mode, the engine outputs its full power, allowing the machine to perform work requiring large production, heavy-load, and uphill work.

E mode (Economy mode)

With E mode, the engine outputs enough power for the work without delivering unnecessary power. This mode enables energy saving operation and is ideal on hard or rough surfaces that often cause shoe slip and work not requiring as much power, such as downhill dozing, leveling and light-load work.

PAT DOZER

Moldboard PAT Dozer with Adjustable Pitch

A high wear-resistant power angle, power tilt dozer blade with adjustable blade pitch is available on the D51EXi/PXi-24. The hydraulic blade tilt and angling function expands versatility and productivity in a variety of applications.



High Productivity

The D51PXi PAT high-capacity (4.4 yd³), high wear-resistant blade can increase production.

Production increased by up to 15%

Compared to standard D51PXi PAT capacity.



Unrivaled Blade Visibility

The D51EXi/PXi-24 incorporates Komatsu's super-slant nose design. Komatsu's innovative design provides excellent blade visibility for improved machine control and increased efficiency and productivity.



CONTROL FEATURES



Photo may include optional equipment.

Palm Command Control System (PCCS) Levers

Komatsu's ergonomically designed PCCS handles create an operating environment with complete operator control.

PCCS

The low-effort PCCS joystick controls all directional movements, including machine travel speed as well as counter-rotation.

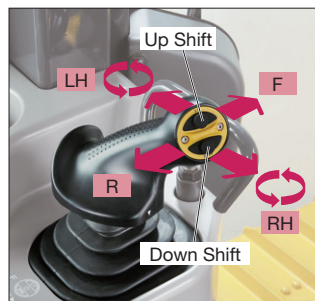

Electronic controlled hydraulic system

Electronic controlled palm commanded joystick provides precise blade control. New blade angling switch operation provides easier and predictable blade control.



HST with Electronic Control

The D51EXi/PXi-24 is equipped with Komatsu-designed HST that allows for Quick-Shift or variable speed selection. The HST consists of dual-path closed-circuits, with two variable displacement piston pumps and two variable displacement travel motors. Hydrostatic steering eliminates steering clutches and brakes, providing smooth, powerful turns. Fully electronic control provides complete automatic shifting and enables smooth control. Engine speed is controlled using an electronic fuel control dial.

One-Pedal Design (Decelerator/Brake Pedal) Controls Speed, During Operation

Machine operation is simple because brake function has been integrated into the decelerator pedal. Machine travel speed can be controlled using one pedal. The pedal function can be changed by a mode selector switch.

Decelerator mode: The pedal modulates engine rpms and vehicle travel speed. It can be used for all applications.

Brake mode: The pedal modulates vehicle travel speed while maintaining high-engine speed. This mode can be helpful to maintain work-equipment speed, while using the brake function.



WORKING ENVIRONMENT



Integrated ROPS (ISO 3471) Cab

The D51EXi/PXi-24 has an integrated ROPS (ISO 3471) cab with Bluetooth radio and LED worklights. High rigidity and superb sealing sharply reduces noise and vibration for the operator and discourages dust from entering the cab. In addition, side visibility is increased because external ROPS (ISO 3471) structure and posts are not required.



Comfortable Ride with Cab Damper Mounting

The D51EXi/PXi-24's cab mount uses a cab damper system that provides excellent shock and vibration absorption which conventional mounting systems are unable to match. The silicon-oil-filled cab damper mount helps to isolate the cab from the machine body, suppressing vibration and providing a quiet, comfortable operating environment.

Auxiliary Input Jack & Two DC12 Volt Electrical Outlets

By connecting an auxiliary device to this plug input, the operator can play audio from a mobile device through the machine's sound system. Two DC12 volt electrical outlets can be used as a power source for radio equipment or other electronics, and there is one DC 24 volt cigarette lighter.



Two DC12 V electrical outlets

Auxiliary input jack

Comfortable Ride with Heated Operator Seat

The operator seat has adjustable lumbar support, tilt and an electric heater. It is easy to adjust to the operator's shape and comfortable operation is possible in a variety of conditions. Also, the seat heat makes it possible to work comfortably in the winter.



ADDITIONAL OPERATOR CONVENIENCE EQUIPMENT

Rear view monitor system

On the large LCD color monitor, the operator can view, through one camera, areas directly behind the machine. This camera can be synchronized with reverse operation.



Secondary engine shutdown switch

A new secondary switch has been added at the side of the front console to shut down the engine in an emergency.



RELIABILITY & MAINTENANCE FEATURES

Excellent Reliability & Durability

Parallel Link Undercarriage System (PLUS)

Komatsu's PLUS rotating bushing design provides less downtime, longer wear, and up to 40% lower undercarriage maintenance costs than a conventional undercarriage. Rotating bushings eliminate the cost and downtime for bushing turns, and strengthened rollers and links increase wear life up to two times. With PLUS, individual links can be replaced with common track tools.

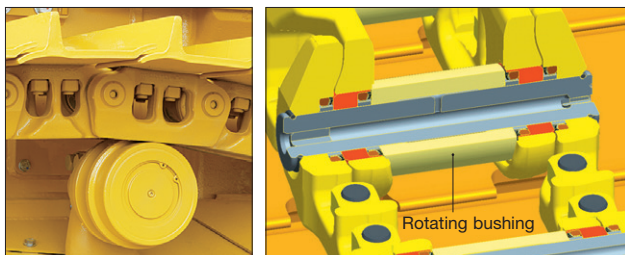

Modular design

One of the design goals behind the creation of the D51EXi/PXi-24 was to manufacture a more durable machine. This was achieved by reducing component complexity and using a strong modular design for increased serviceability and durability.

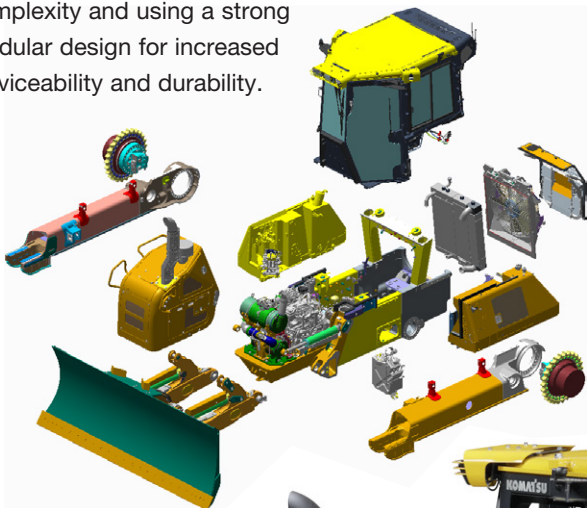

Self-adjusting idler support

The self-adjusting idler support provides constant and even tension on idler guide plates, reducing noise and vibration and increasing undercarriage life.

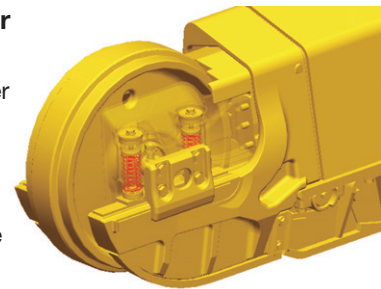

Easy Maintenance

Planned maintenance and daily checks are the only way to ensure long service life from equipment. That's why Komatsu designed the D51EXi/PXi-24 with conveniently located maintenance points to make necessary inspections and maintenance quick and easy.

Rear, hydraulically-driven, swing-up fan

The D51EXi/PXi-24 utilizes a swing-up fan with a gas strut-assisted lift system to provide easy access to the (side-by-side) radiator, oil cooler and charge air cooler. The hydraulic fan is reversible to help keep the radiator cores clean and simplify maintenance.

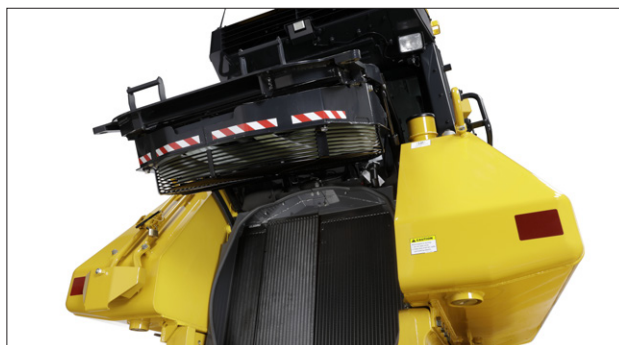

D51PX-24 shown

TECHNOLOGY FEATURES



Large Multi-Lingual High Resolution LCD Monitor

A large, user-friendly color monitor provides easy-to-understand information for the operator. Excellent screen visibility is achieved with a high resolution LCD monitor that is easy to read at various angles and lighting conditions. Simple and easy-to-operate switches and function keys facilitate multi-function operations. The monitor displays data in 26 languages.



Multi-monitor with Troubleshooting Function to Minimize Down Time

Various meters, gauges and warning functions are centrally arranged on the multi-monitor. The monitor simplifies start-up inspection and promptly warns the operator with a lamp and buzzer if any abnormalities occur. In addition, warning indicators are displayed in 4 levels to alert the operator of potential issues. Replacement times for required PM services are also indicated.



Energy Saving Operation

Ecology guidance

In order to support efficient operation, the following four messages are displayed for fuel saving operation. These can be displayed by the operator, if desired.

- 1) Avoid Excessive Engine Idling
- 2) Use Economy Mode to Save Fuel
- 3) Avoid Hydraulic Relief Pressure
- 4) Avoid Over Load

Ecology gauge Ecology guidance



Fuel consumption display

Ecology gauge

To help the operator to perform in an environmentally friendly way and minimize energy consumption, an easy-to-read "Ecology gauge" is displayed on the left of the multi-monitor screen.

Fuel consumption display

Average fuel consumption during the day is displayed and updated every 10 seconds.

KOMTRAX Web Based Reports

KOMTRAX is Komatsu's remote equipment and fleet monitoring system. Wireless technology and a secure web-based application communicate the information needed to make the best possible operation and management decisions. From location, actual hours worked and fuel consumption, to maintenance monitoring, abnormality codes and load frequency, operators receive reports that are simple to read and understand. The new D51EXi/PXi-24 adds the following new information for fuel consumption reduction.

- Guidance to improve fuel consumption
- Operating hours by operation mode (E or P mode)
- Service information for U.S. EPA Tier 4 Final emissions system

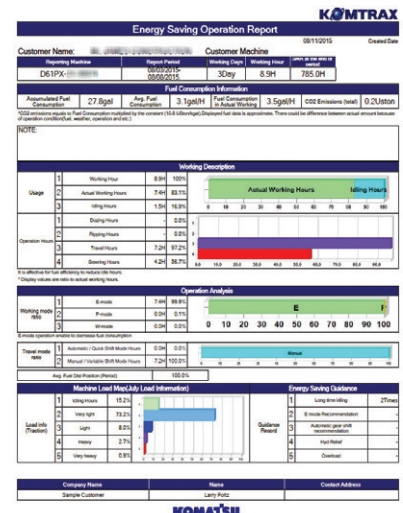

KOMATSU PARTS & SERVICE SUPPORT



Komatsu CARE®

Program Includes:

*The D51EXi/PXi-24 comes standard with complimentary factory scheduled maintenance for the first 3 years or 2,000 hours, whichever occurs first.

Planned Maintenance Intervals at:

500/1000/1500/2000 hour intervals. (250 hr. initial interval for some products) Complimentary Maintenance Interval includes: Replacement of Oils & Fluid Filters with genuine Komatsu Parts, 50-Point inspection, Komatsu Oil & Wear Analysis Sampling (KOWA) / Travel & Mileage (distance set by distributor; additional charges may apply).

Benefits of Using Komatsu CARE

- Assurance of Proper Maintenance with OEM Parts & Service
- Increased Uptime & Efficiency
- Factory Certified Technicians Performing Work
- Cost of Ownership Savings
- Transferable Upon Resale

Complimentary SCR System Maintenance

The D51EXi/PXi-24 also includes 2 factory suggested services of the Selective Catalytic Reduction (SCR) Diesel exhaust fluid (DEF) system during the first 5 years or 9,000 hours, whichever occurs first, including:

- Factory suggested DEF tank flush and strainer cleaning at 4,500 hours and 9,000 hours

KOMATSU CARE D51EXi/PXi-24

| Interval PM | 500 | 1000 | 1500 | 2000 |
|--|-----|------|------|------|
| KOWA SAMPLING – (Engine, Hydraulics, L & R Final Drives) | ✓ | ✓ | ✓ | ✓ |
| LUBRICATE MACHINE, INCLUDING EQUALIZER BAR CENTER AND SIDE PINS | ✓ | ✓ | ✓ | ✓ |
| CHANGE ENGINE OIL | ✓ | ✓ | ✓ | ✓ |
| REPLACE ENGINE OIL FILTER | ✓ | ✓ | ✓ | ✓ |
| REPLACE FUEL PRE-FILTER | ✓ | ✓ | ✓ | ✓ |
| REPLACE A/C FRESH & RECIRCULATION FILTERS | ✓ | ✓ | ✓ | ✓ |
| DRAIN SEDIMENT FROM FUEL TANK | ✓ | ✓ | ✓ | ✓ |
| CLEAN AIR CLEANER ELEMENT | ✓ | ✓ | ✓ | ✓ |
| COMPLETE 50 POINT INSPECTION FORM; LEAVE PINK COPY WITH CUSTOMER OR IN CAB | ✓ | ✓ | ✓ | ✓ |
| RESET MONITOR PANEL MAINTENANCE COUNTER FOR APPROPRIATE ITEMS | ✓ | ✓ | ✓ | ✓ |
| REPLACE FUEL MAIN FILTER | | ✓ | | ✓ |
| REPLACE FUEL TANK BREATHER ELEMENT | | ✓ | | ✓ |
| REPLACE DEF TANK BREATHER ELEMENT | | ✓ | | ✓ |
| REPLACE HYDRAULIC TANK BREATHER ELEMENT | | ✓ | | ✓ |
| CHANGE FINAL DRIVE OIL | | ✓ | | ✓ |
| CHANGE HYDRAULIC OIL | | | | ✓ |
| REPLACE HYDRAULIC FILTER | | | | ✓ |
| REPLACE HST FILTER | | | | ✓ |
| REPLACE KCCV FILTER | | | | ✓ |
| CLEAN HYDRAULIC TANK STRAINER | | | | ✓ |
| REPLACE DEF PUMP FILTER | | | | ✓ |
| FACTORY TRAINED TECHNICIAN LABOR | ✓ | ✓ | ✓ | ✓ |

2 SCR System Maintenance Services suggested at 4,500 Hrs. and 9,000 Hrs.

Komatsu CARE® – Advantage Extended Coverage

- Extended Coverage can provide peace of mind by protecting customers from unplanned expenses that effect cash flow
- Purchasing extended coverage locks-in the cost of covered parts and labor for the coverage period and helps turn these into fixed costs



Komatsu Parts Support

- 24/7/365 to fulfill your parts needs
- 9 parts Distribution Centers strategically located across the U.S. and Canada
- Distributor network of more than 300 locations across U.S. and Canada to serve you
- Online part ordering through Komatsu eParts
- Remanufactured components with same-as-new warranties at a significant cost reduction



Komatsu Oil and Wear Analysis (KOWA)

- KOWA detects fuel dilution, coolant leaks, and measures wear metals
- Proactively maintain your equipment
- Maximize availability and performance
- Can identify potential problems before they lead to major repairs
- Reduce life cycle cost by extending component life

* Certain exclusions and limitations apply. Refer to the customer certificate for complete program details and eligibility. Komatsu® and Komatsu Care® are registered trademarks of Komatsu Ltd. Copyright 2019 Komatsu America Corp.

D51EXi/PXi-24

KOMTRAX EQUIPMENT MONITORING



GET THE WHOLE STORY WITH
KOMTRAX[®]

✓ **WHAT**

- KOMTRAX is Komatsu's remote equipment monitoring and management system
- KOMTRAX **continuously monitors and records** machine health and operational data
- Information such as fuel consumption, utilization, and a detailed history **lowering owning and operating cost**

✓ **WHEN**

- Know when your machines are **running or idling** and make decisions that will improve your fleet utilization
- Detailed movement records ensure you know when and where your equipment is moved
- Up to date records allow you to **know when maintenance is due** and help you plan for future maintenance needs

✓ **WHERE**

- KOMTRAX data **can be accessed virtually anywhere** through your computer, the web or your smart phone
- Automatic alerts keep fleet managers up to date on the latest machine notifications

✓ **WHO**

- KOMTRAX is **standard** equipment on all Komatsu construction products

✓ **WHY**

- Knowledge is power - **make informed decisions** to manage your fleet better
- Knowing your idle time and fuel consumption will help maximize your machine efficiency
- **Take control of your equipment** - any time, anywhere



For construction and compact equipment.

SPECIFICATIONS



ENGINE

Model.....Komatsu SAA4D107E-7*
 Type4-cycle, watercooled, direct injection
 Aspiration.....Variable geometry, turbocharged,
 air-to-air aftercooled
 Number of cylinders..... 4
 Bore x stroke..... 107 mm x 124 mm **4.21" x 4.88"**
 Piston displacement..... 4.5 ltr **275 in³**
 Governor.....All-speed, electronic
 Horsepower
 SAE J1995.....Gross 99 kW **133 HP**
 ISO 9249 / SAE J1349.....Net 98 kW **131 HP**
 Hydraulic fan at maximum speed.....Net 91 kW **122 HP**
 Rated rpm.....2200 rpm
 Fan drive type.....Hydraulic
 Lubrication system
 Method.....Gear pump, force lubrication
 Filter.....Full-flow

*EPA Tier 4 Final emissions certified



HYDROSTATIC TRANSMISSION

Dual-path, hydrostatic transmission provides infinite speed changes up to 9.0 km/h **5.6 mph**. The variable capacity travel motors allow the operator to select the optimum speed to match specific jobs. Travel control lock lever and neutral switch.

| Travel speed (quick shift mode)* | Forward | Reverse |
|----------------------------------|-----------------------------|-----------------------------|
| 1st | 0-3.4 km/h 0-2.1 mph | 0-4.1 km/h 0-2.5 mph |
| 2nd | 0-5.6 km/h 0-3.5 mph | 0-6.5 km/h 0-4.0 mph |
| 3rd | 0-9.0 km/h 0-5.6 mph | 0-9.0 km/h 0-5.6 mph |

| Travel speed (variable mode) | Forward | Reverse |
|------------------------------|-----------------------------|-----------------------------|
| | 0-9.0 km/h 0-5.6 mph | 0-9.0 km/h 0-5.6 mph |

*Quick shift speeds are adjustable in the monitor.

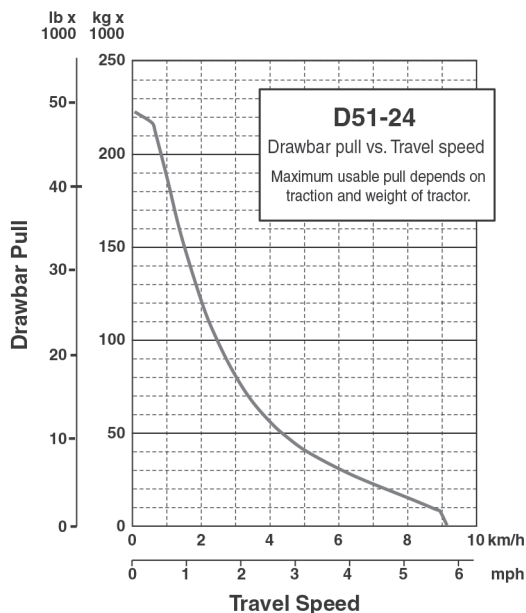

FINAL DRIVES

In-shoe mounted, axial-piston-type travel motors, with integrated two-stage planetary gear reduction. Compact, in-shoe mount reduces risk of damage by debris. Bolt-on sprocket ring with triple labyrinth seal design.



STEERING SYSTEM

Palm Command Control System (PCCS) joystick control for all directional movements. Pushing the joystick forward results in forward machine travel, while pulling it back reverses the machine. Simply tilt the joystick to the left or right to make a turn. Tilting the joystick fully to the left or right activates counter-rotation.

Hydrostatic Transmission (HST) provides smooth, powerful turns. Fully electronic control enables smooth control that can be adjusted in the monitor. The PCCS utilizes shift buttons to increase and decrease speed.

Minimum turning radius*

D51EXi-24 2.4 m **94"**

D51PXi-24 2.6 m **102"**

*As measured by track marks on the ground at pivot turn.



UNDERCARRIAGE

SuspensionRigid type
 Track roller frame Monocoque, large section, durable construction
 Rollers & idlersLubricated track rollers

Sealed & lubricated track...Track tension easily adjusted w/grease gun

| | D51EXi-24 | D51PXi-24 |
|--|------------------------------|------------------|
| Number of track rollers (each side) | 7 | 7 |
| Type of shoes (standard) | Single grouser | Single grouser |
| Number of shoes (each side) | 44 | 44 |
| Grouser height | mm in 55 2.2" | 55 2.2" |
| Shoe width (standard) | mm in 560 22" | 710 28" |
| Ground contact area | cm ² 30750 | 38980 |
| | in ² 4,766 | 6,042 |
| Ground pressure (with dozer, ROPS cab) | kPa 39.4 | 32.0 |
| (ISO 16754) | kgf/cm ² 0.40 | 0.33 |
| | psi 5.71 | 4.64 |
| Track gauge | mm ft.in 1790 5'10" | 1880 6'2" |
| Length of track on ground | mm ft.in 2745 9'0" | 2745 9'0" |



SERVICE REFILL CAPACITIES

Coolant 37 ltr **9.8 U.S. gal**
 Fuel tank 270 ltr **71.3 U.S. gal**
 Engine oil 16 ltr **4.2 U.S. gal**
 Hydraulic tank 64 ltr **17 U.S. gal**
 Final drive (each side)..... 5.5 ltr **1.5 U.S. gal**
 Diesel Exhaust Fluid (DEF) tank20.5 ltr **5.42 U.S. gal**



OPERATING WEIGHT (APPROXIMATE)

Tractor weight:

Including ROPS cab, U frame for Power Angle Tilt (PAT) dozer, rated capacity of lubricant, coolant, full fuel tank, operator, and standard equipment.

D51EXi-24..... 12110 kg **26,698 lb**

D51PXi-24..... 12470 kg **27,492 lb**

Operating weight:

Including Power Angle Tilt (PAT) dozer, ROPS cab, operator, standard equipment, rated capacity of lubricant, hydraulic control unit, coolant, and full fuel tank.

D51EXi-24..... 13780 kg **30,380 lb**

D51PXi-24..... 14260 kg **31,438 lb**



DIMENSIONS

| | D51EXi-24 | | D51PXi-24 | |
|---|-----------|--------------|-----------|---------------|
| A | 3045 mm | 10' | 3350 mm | 11' |
| B | 425 mm | 1'5" | 470 mm | 1'7" |
| C | 1120 mm | 3'8" | 1170 mm | 3'10" |
| D | 1015 mm | 3'4" | 1035 mm | 3'5" |
| E | 455 mm | 1'6" | 475 mm | 1'7" |
| F | 2745 mm | 9' | 2745 mm | 9' |
| G | 4800 mm | 15'9" | 4850 mm | 15'11" |
| H | 3176 mm | 10'5" | 3176 mm | 10'5" |
| I | 55 mm | 2.2" | 55 mm | 2.2" |
| J | 1790 mm | 5'10" | 1880 mm | 6'2" |
| K | 560 mm | 22" | 710 mm | 28" |
| L | 2350 mm | 7'9" | 2590 mm | 8'6" |
| M | 2720 mm | 8'11" | 2990 mm | 9'10" |
| N | 5485 mm | 18' | 5605 mm | 18'5" |

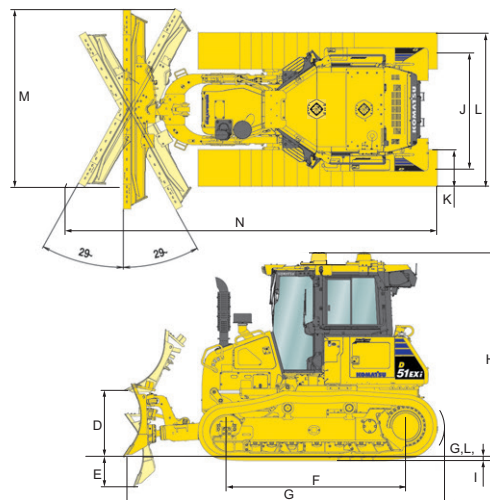
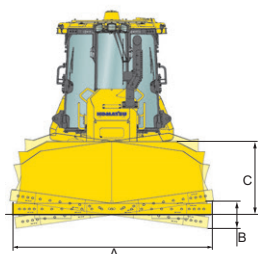

Ground clearance 390 mm **15"**



HYDRAULIC SYSTEM

Closed-Center Load Sensing System (CLSS) designed for precise and responsive control, and for efficient simultaneous operation.

Hydraulic control unit:

All spool control valves externally mounted remote to the hydraulic tank. Piston-type hydraulic pump with capacity (discharge flow) of 97 ltr/min **26 U.S. gal/min** at rated engine rpm.

Relief valve setting 27.4 MPa 280 kg/cm² **3,974 psi**
 Hydraulic cylinders Double-acting, piston type

| | Number of cylinders | Bore |
|-------------|---------------------|-------------------|
| Blade lift | 2 | 90 mm 3.5" |
| Blade tilt | 1 | 100 mm 4" |
| Blade angle | 2 | 90 mm 3.5" |

Hydraulic oil capacity (refill):

Power angle tilt dozer 64 ltr **17 U.S. gal**

Control valves:

3-spool control valve for Power Angle Tilt dozer

Positions:

Blade lift Raise, hold, lower, and float
 Blade tilt Right, hold, and left
 Blade angle Right, hold, and left

Additional control valve required for ripper

Positions:

Ripper lift Raise, hold, and lower



DOZER EQUIPMENT

| | Overall Length With Dozer mm ft.in | Blade Capacity m ³ yd ³ | Blade Width x Height mm ft.in | Max. Lift Above Ground mm ft.in | Max. Drop Below Ground mm ft.in | Max. Tilt Adjustment mm ft.in |
|--|---------------------------------------|--|----------------------------------|------------------------------------|------------------------------------|----------------------------------|
| D51EXi-24 | 4800 | 2.7 | 3045 x 1120* | 1015 | 455 | 425 |
| Power Angle Tilt Dozer | 15'9" | 3.5 | 10' x 3'8" | 3'4" | 1'6" | 1'5" |
| D51PXi-24 | 4850 | 3.4 | 3350 x 1170 | 1035 | 475 | 470 |
| Power Angle Tilt Dozer (High-capacity) | 15'11" | 4.4 | 11' x 3'10" | 3'5" | 1'7" | 1'7" |

Blade capacities are based on the recommended practice ISO 9246. Use of high-tensile-strength steel in moldboard for strengthened blade construction.

*Optional PAT Dozer Assembly (EXi), 11' x 3' 10" (3350 mm x 1170 mm) wide



STANDARD EQUIPMENT FOR BASE MACHINE*

- Accumulator for Electric Proportional Control (EPC)
- Air cleaner, dry, double element type with caution lamp on monitor
- Air conditioner (A/C)
- Air inlet
- Alternator, 24 V/85 A
- Back-up alarm
- Batteries, large capacity 24 V/92 Ah
- Cab accessories
 - 12 V x 2 power supply
 - Cup holder
 - Rear view mirror
 - Rear view monitor system
 - Bluetooth/USB compatible radio with remote AUX plug (3.5 mm)
- Crankcase guard and underguard
- Decelerator/brake pedal (Single pedal)
- Electronically controlled Hydrostatic Transmission (HST) with quick-shift and variable speed settings
- Electronic monitor panel with on-board diagnostics
- Engine hood and side panels
- Engine, KOMATSU SAA4D107E-3, gross output of 98 kW **131 HP**, direct injection, water-cooled turbocharged, air-to-air aftercooler, cooled EGR, EPA Tier 4 Final and EU Stage 4 emissions certified
- Fan, hydraulic driven, electronic control
- Filler cap locks and cover locks
- Fluid sampling ports
- Foot rest, high mounted
- Fuel pre-filter (10 micron) and fuel filter (2 micron)
- Grease gun holder
- High altitude arrangement (No fuel adjustment up to 2300 m)
- Horn
- Hydraulics for PAT dozer
- Intake pipe with precleaner
- intelligent Machine Control 2.0
- Komatsu Diesel Oxidation Catalyst (KDOC)
- KOMTRAX Level 5.0
- Large high-resolution LCD
- LED worklights
- Lunch box holder
- Marks and plates, English
- New Operator Identification System
- Palm Command Control System (PCCS) with electronic control for travel control
- Palm Command Control System (PCCS) with EPC for blade control
- Power turn with counter rotation
- Pullhook, front
- Radiator guard grid
- Radiator reserve tank
- Real-time DEF monitoring

- Rear-hinged radiator guard
- Reverse travel speed presets
- ROPS cab
 - Meets ISO 3471, SAE J/ISO 3471 ROPS standards, and ISO 3449 FOPS standard.
- Seat belt, 76 mm **3"** retractable
- Seat, air suspension, fabric, heated, low back, headrest
- Starting motor, 24 V/4.5 kW
- Selective Catalytic Reduction (SCR)
- Self adjusting roller
- Sprockets, bolt-on
- Sprocket inner guard
- Track roller guards, end section
- Track shoe assembly (PLUS)
 - Sealed and lubricated
- D51EXi-24: 560 mm **22"** single grouser shoe
- D51PXi-24: 710 mm **28"** single grouser shoe
- Triple labyrinth final drive
- Water separator

Dozer assembly and rear-mounted equipment are not included in base machine price.



OPTIONAL EQUIPMENT

- Dozer assembly
- Hitch
- Hydraulics for rear equipment
- Track roller guard, full length

Multi-shank ripper (for D51EXi only)

| | |
|--------------------------------|------------------------|
| Weight..... | 860 kg 1,874 lb |
| Beam length..... | 1556 mm 5'1" |
| Maximum lift above ground..... | 380 mm 1'3" |
| Maximum digging depth..... | 425 mm 1'8" |
| Number of shanks..... | 3 |



ALLIED MANUFACTURER'S ATTACHMENTS (SHIPPED LOOSE)

- Guarding - Komatsu
 - Front sweeps 258 kg **569 lb**
 - Hinged cab side screens 44 kg **97 lb**
 - Hinged cab rear screen 43 kg **95 lb**
 - Rear A/C guard (requires front sweep) 61 kg **134 lb**
- Hydraulic winch - Allied H5C (without wire rope) 953 kg **2,101 lb**



Note: All comparisons and claims of improved performance made herein are made with respect to the prior Komatsu model unless otherwise specifically stated.